

172x150x51mm

■ Model B

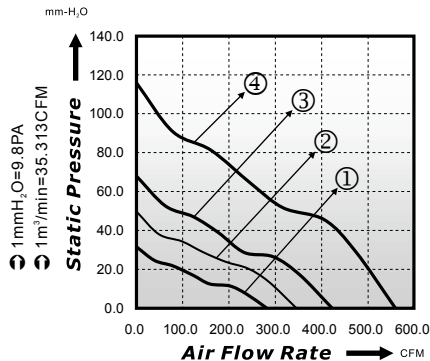

■ P-Q Curve (At Rated Voltage)



■ Dimensions Drawing

Unit: (mm)

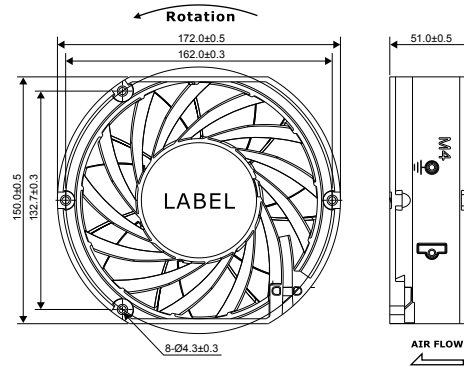

Model No	Bearing (*)	Rated Voltage (VDC)	Rated Current (A)	Power Consumption (Watts)	Speed (rpm)	Air Flow (CFM)	Static Pressure (mmH ₂ O)	Noise (dBA)	Curve
ED17251-12L*	●	12	2.44	29.28	4000	281.5	35.6	61.5	1
ED17251-12M*	●	12	3.80	45.60	5000	345.5	49.8	66.8	2
ED17251-24L*	●	24	1.22	29.28	4000	281.5	35.6	61.5	1
ED17251-24M*	●	24	3.38	81.12	6000	422.5	68.0	69.5	3
ED17251-48L*	●	48	0.61	29.28	4000	281.5	35.6	61.5	1
ED17251-48M*	●	48	1.69	81.12	6000	422.5	68.0	69.5	3
ED17251-48H*	●	48	3.65	175.20	8000	559.0	116.0	76.5	4

* Bearing Type: ○ Sleeve ● Two Ball ⊙ Hydro-Dynamic